

PDCN	REV.	APPV DATE	REVISIONS	DWN	DSGN	CHK	APPV
2006318	1	10/06/06	INITIAL ISSUE	RSR	AA	DRL	AA
2006364	2	01/25/07	FIELD CDIL PART NUMBER: 0432-6340 WAS 0432-6040	RSR	BC	DRL	YN
2006440	3	01/25/07	FDIL WINDING 0432-6340 "6FZ" WAS 0432-6040 "6EK" ADDED: (140); 195±10 WAS 210±10	TG	JW	AA	EMA
2008019	4	3/10/08	UPDATED TO SHOW LATEST CHANGES: 4695-0452 REV A WAS 4695-0451 REV D	DRL	NB	J.S.	HF
9373	5	9-26-11	ADDED NOTE 3. CHANGED DESCRIPTION.				

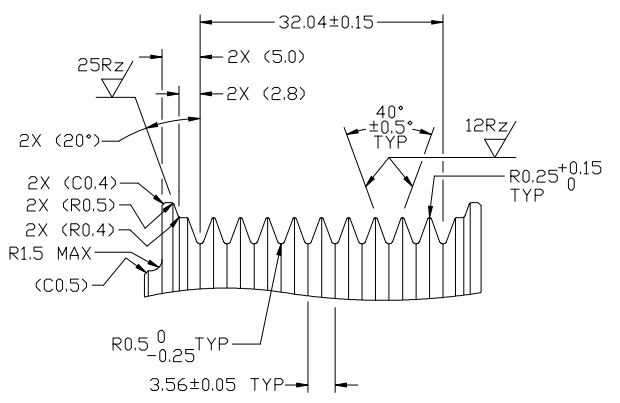

DETAIL B  
SCALE 2:1

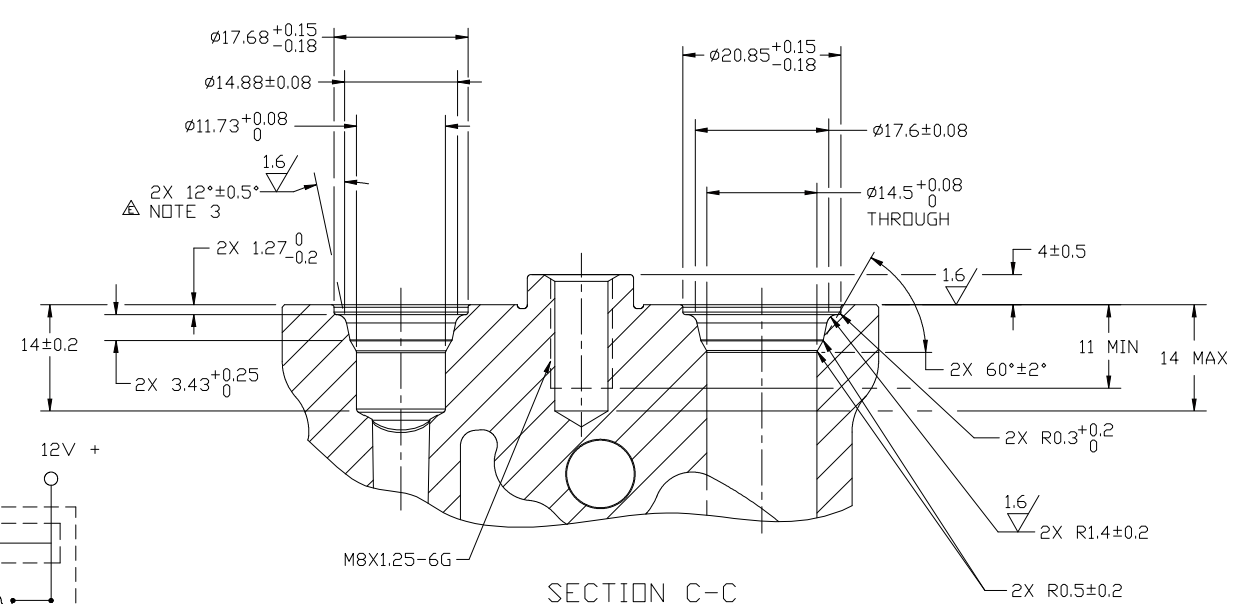

SECTION C-C  
SCALE 2:1

(SHIPPING PAD AND BOLT REMOVED, SECTION ROTATED 90° CCW)

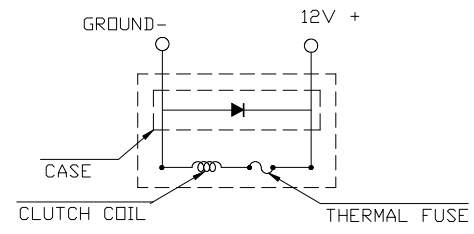

CIRCUIT DIAGRAM  
(FOR REFERENCE)

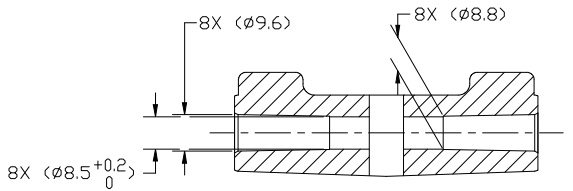

SECTION A-A

HEX FLANGE BOLT  
M8 X 1.25-6g  
LENGTH (18)

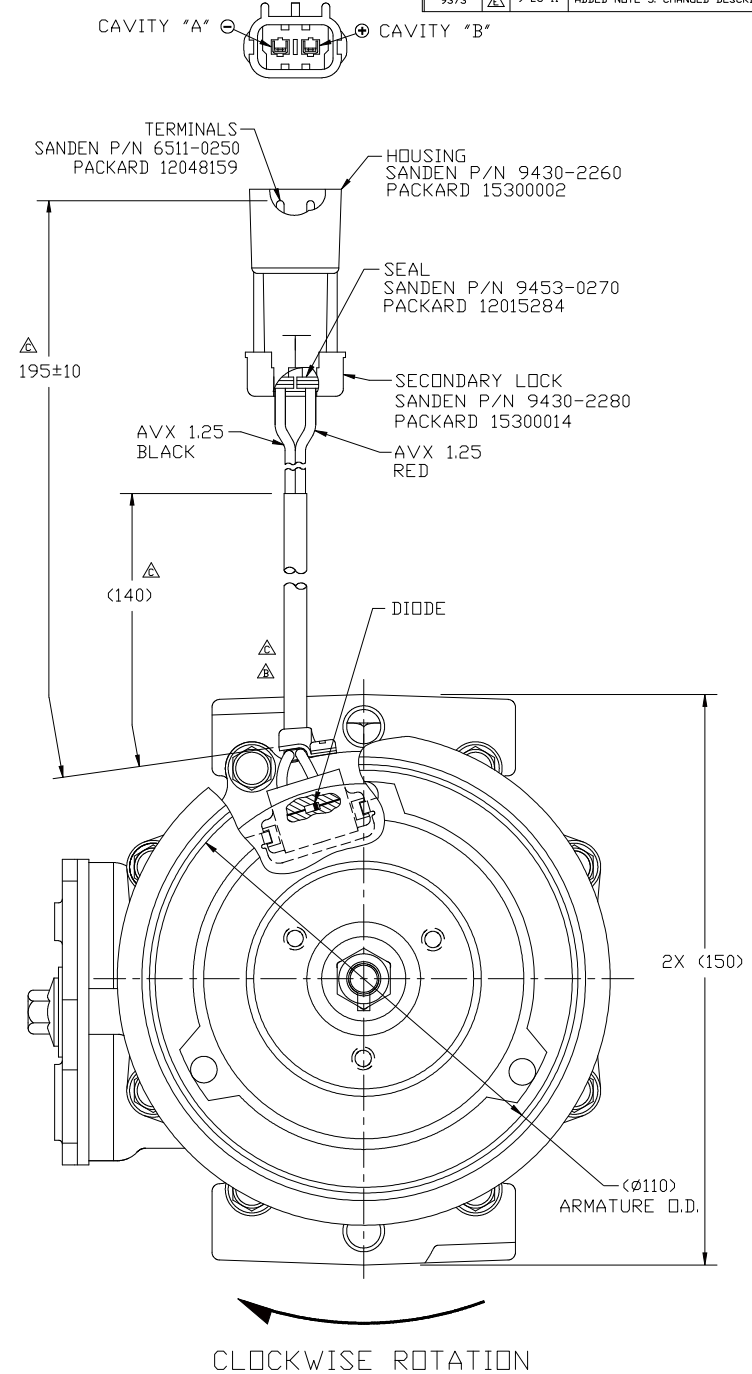
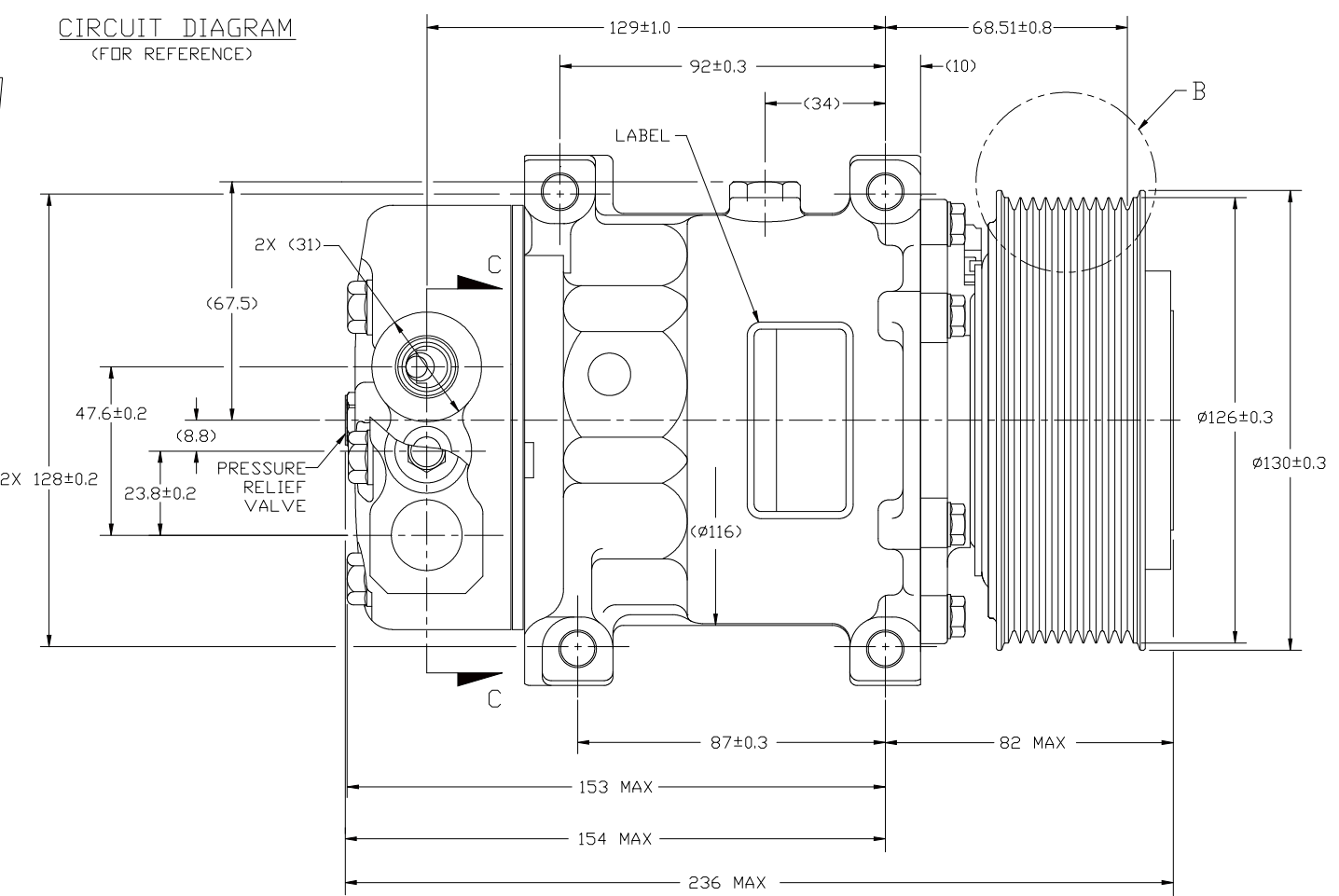
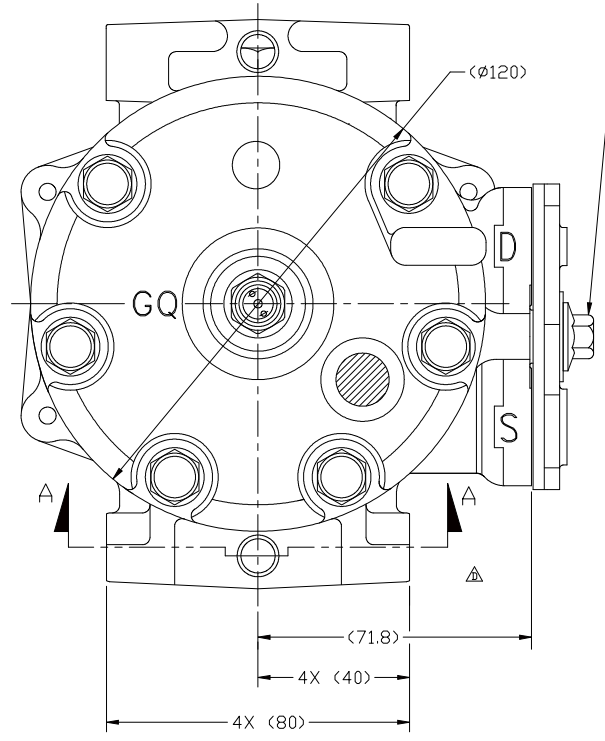

CLOCKWISE ROTATION

COMPRESSOR SPECIFICATIONS (REF)

DISPLACEMENT PER REVOLUTION	154.9 cc / rev. ( 9.5cu.in. / rev. )
MAXIMUM ALLOWABLE R.P.M.	8000 R.P.M.
MAXIMUM ALLOWABLE CONTINUOUS R.P.M.	6000 R.P.M.
REFRIGERANT	R134a
OIL ( SP-15 )	300 cc ( 10.1 fl.oz. )

CLUTCH SPECIFICATIONS (REF)

RATED VOLTAGE	DC 12V
BREAKAWAY TORQUE	3.5 kgf-m min. @ 12V
MINIMUM ENGAGEMENT VOLTAGE	7.5V @ AIR GAP 0.6mm
POWER CONSUMPTION	49 watts max.
BELT TYPE	PV10 TYPE
MAXIMUM ALLOWABLE BELT TENSION	120 kgf
PULLEY DIAMETER	Ø126 mm ( 4.96 in. )
CLUTCH TYPE	HEAVY DUTY

NOTE:

- DIMENSIONS ARE TO VIRTUAL SHARP CORNERS UNLESS OTHERWISE SPECIFIED.
- COMPRESSOR TO BE CHARGED WITH NITROGEN PRIOR TO SHIPPING WITHIN 0.2 TO 1.6 kg/cm<sup>2</sup>.
- THIS COMPRESSOR MODEL IS INTENDED FOR SALE TO PACCAR ONLY.

DO NOT SCALE

REV. LEVEL	RELEASED FOR: ENGG DEVELOPMENT	<p>SANDEN INTERNATIONAL ( U.S.A. ), INC.</p>	<p>DRAWN SCALE REF 1:1 PLOTTED SCALE REF NONE METRIC</p>
DSGN	Aiferdo Armendariz		
CHK	J Sokolowski	<p>INTERPRETATION OF THIS DRAWING PER ASME Y14.5M-1994</p>	<p>THIRD ANGLE PROJECTION</p>
APPV	Aiferdo Armendariz		
DATE	9/19/06	<p>MATERIAL:</p>	<p>NAME</p>
REV. LEVEL	RELEASED FOR: DESIGN VALIDATION		
DSGN	Aiferdo Armendariz	<p>COMPRESSOR (PACCAR ONLY)</p>	<p>REV. LEVEL</p>
APPV	Aiferdo Armendariz		
DATE	9/19/06	<p>DWG NO. 4384-6000</p>	<p>REV. LEVEL</p>
REV. LEVEL	RELEASED FOR: PRODUCTION		
DSGN	C. Wolff	<p>REV. LEVEL</p>	
APPV	E. M. Arrieta		
DATE	9/19/06	<p>REV. LEVEL</p>	
REV. LEVEL	RELEASED FOR: PRODUCTION		